

Kodiak Product Range

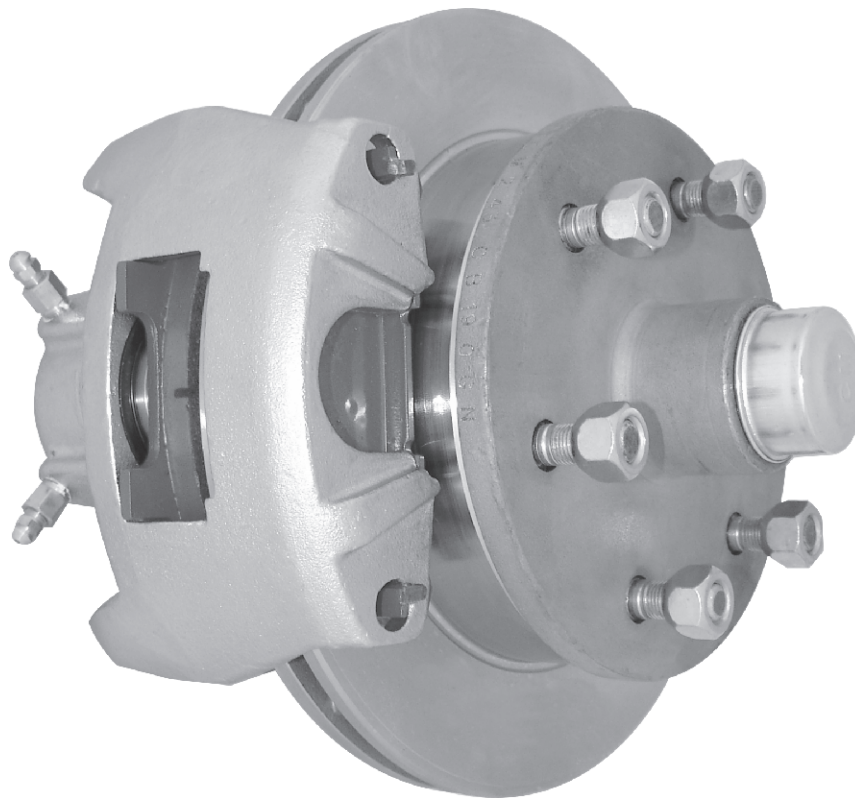

HYDRAULIC VENTED DISC BRAKES

1500kg - 1750kg - 2000kg

**UP TO
6 YEAR
WARRANTY**

Kodiak disc brakes could be the best investment you will ever make. Superior strength, advanced design and corrosion protection make Kodiak the best performing disc brake on the market. Choose from either Silver Cadmium Plated (SCAD) or Stainless Steel vented rotors and calipers.

Choose vented rotors for greater heat dissipation, improved braking performance and less susceptibility to brake fade and warpage. All rotors are balanced with minimal runout.



**OPTIONAL ALL
STAINLESS
STEEL
PACKAGE**



- **Now available to fit up to 6 stud 5 1/2" (140mm) PCD.**
- **Guaranteed performance** - exceeds CSA-D313 test requirements.
- **Vented rotors** - run cooler and improve braking performance.
- **Ceramic pads** - improve performance plus 50% - 100% longer pad life.
- **Longest warranty in the industry** - 6 years Stainless Steel / 3 years Silver Cadmium Plated. Conditions apply.
- **Large pistons** - 2 1/4", largest in the industry.
- **Large diameter rotors** - 11", 22% larger than the opposition, giving more braking force per revolution.
- **Stainless Steel or SCAD plated cast iron rotors** - choose between the two: stainless steel for optimum corrosion resistance or SCAD plated cast iron rotors for the best value for money.
- **Galvanised SG Iron hubs** - machined from quality SG Iron castings and galvanised for maximum protection.
- **Proven reliability** - over 20 years in the automotive and 10 years in the trailer industry.
- **Park brake facility** - stub axles also available with a twin mount to fit a mechanical park brake caliper (standard on 2000kg) required for trailers over 2500kg GLW. See page 11.
- **Marine quality triple lip seals** - all these disc brakes are fitted with triple lip marine quality seals for optimum wheel bearing protection.
- **Fits most 13" galvanised OEM spoke boat trailer wheels** and the majority of 14", 15" and 16".

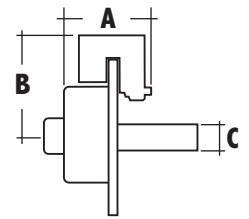

PART NO	CAPACITY PER PAIR	A	B	C	11" ROTOR	CALIPERS	CALIPER SIZE	PCD Min-Max (mm)
TE2DIHK151	1500kg	158mm	150mm	39mm	SCAD Plated	SCAD Plated	2 1/4"	100-140mm
TE2DIHK152	1500kg	158mm	150mm	39mm	SCAD Plated	STAINLESS STEEL	2 1/4"	100-140mm
TE2DIHK153	1500kg	158mm	150mm	39mm	STAINLESS STEEL	STAINLESS STEEL	2 1/4"	100-140mm
TE2DIHK171	1750kg	158mm	150mm	45mm	SCAD Plated	SCAD Plated	2 1/4"	100-140mm
TE2DIHK172	1750kg	158mm	150mm	45mm	SCAD Plated	STAINLESS STEEL	2 1/4"	100-140mm
TE2DIHK173	1750kg	158mm	150mm	45mm	STAINLESS STEEL	STAINLESS STEEL	2 1/4"	100-140mm
TE2DIHK201	2000kg	158mm	150mm	50mm	SCAD Plated	SCAD Plated	2 1/4"	108-140mm
TE2DIHK202	2000kg	158mm	150mm	50mm	SCAD Plated	STAINLESS STEEL	2 1/4"	108-140mm
TE2DIHK203	2000kg	158mm	150mm	50mm	STAINLESS STEEL	STAINLESS STEEL	2 1/4"	108-140mm

REPRODUCTION IN WHOLE OR PART IS PROHIBITED WITHOUT WRITTEN APPROVAL

HYDRAULIC VENTED DISC BRAKES

3500kg

**UP TO
6 YEAR
WARRANTY**

Kodiak 3500kg disc brakes could be the best investment you will ever make. Superior strength, advanced design and corrosion protection make Kodiak the best performing disc brake on the market. Choose from either Silver Cadmium Plated (SCAD) or Stainless Steel vented rotors and calipers.

Large 12" vented rotors for greater heat dissipation, improved braking performance and less susceptibility to brake fade and warpage. All rotors are balanced with minimal runout.



**OPTIONAL ALL
STAINLESS
STEEL
PACKAGE**

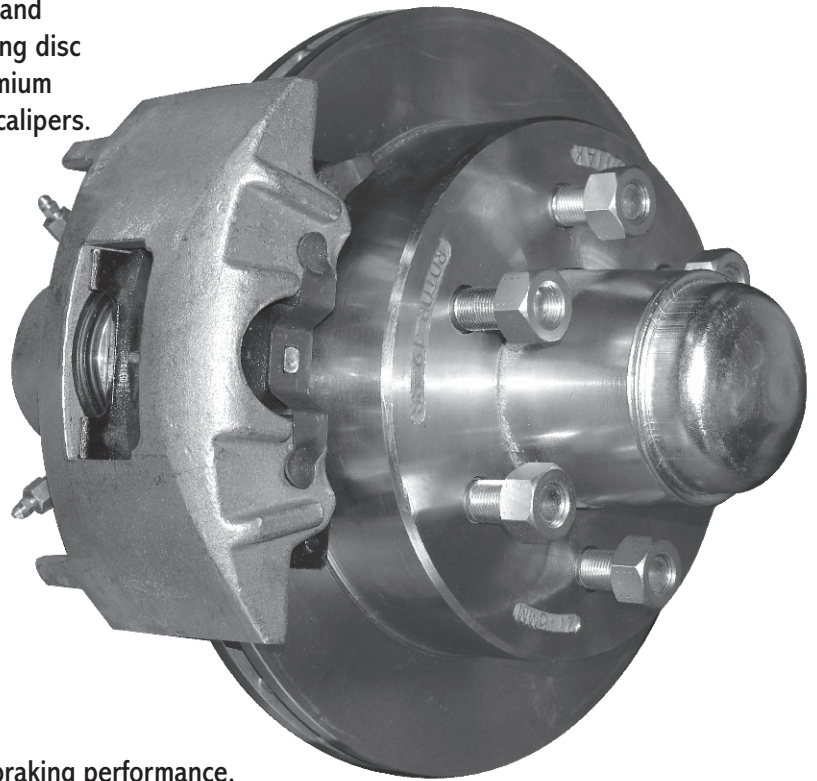

- **Heavy duty 2 1/2" piston caliper** - for superior braking performance.
- **Vented 12" rotors** - run cooler and improve braking performance.
- **4 lip hub seal** - for optimum wheel bearing protection in marine applications.
- **Park brake facility** - all stub axles have a twin mount to fit a mechanical park brake caliper, required for trailers over 2500kg GLW.
- **Guaranteed performance** - exceeds CSA-D313 test requirements.
- **Ceramic pads** - improve performance plus 50% - 100% longer pad life.
- **Longest warranty in the industry** - 6 years Stainless Steel / 3 years Silver Cadmium Plated. Conditions apply.
- **Stainless Steel or SCAD plated cast iron rotors** - choose between the two: stainless steel for optimum corrosion resistance or SCAD plated cast iron rotors for the best value for money.
- **SG Iron hubs** - machined from quality SG Iron castings and zinc electroplated.
- **Proven reliability** - over 20 years in the automotive and 10 years in the trailer industry.
- **Fits 15" and 16"** - 5.50" (140mm) PCD.

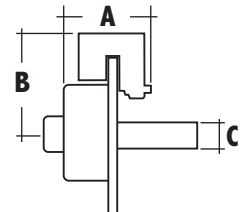

PART NO	CAPACITY PER PAIR	A	B	C	12" ROTOR	CALIPERS	CALIPER SIZE	PCD Min-Max
TE2DIHK351	3500kg	162mm	179mm	60mm dia.	SCAD Plated	SCAD Plated	2 1/2"	5 1/2" (140mm) 6 Stud
TE2DIHK352	3500kg	162mm	179mm	60mm dia.	SCAD Plated		2 1/2"	
TE2DIHK353	3500kg	162mm	179mm	60mm dia.			2 1/2"	

REPRODUCTION IN WHOLE OR PART IS PROHIBITED WITHOUT WRITTEN APPROVAL

HYDRAULIC VENTED DISC BRAKES

Kodiak/Trojan Bolt-on 1500kg Brake Conversion Adaptor

Now you have the opportunity to retrofit Kodiak Vented Disc Brakes to existing Trojan 1500kg axles, MK3 - MK7 (April 1997 onwards)

- **Quick and easy to install** - no engineering required , it is a simple fit the parts installation

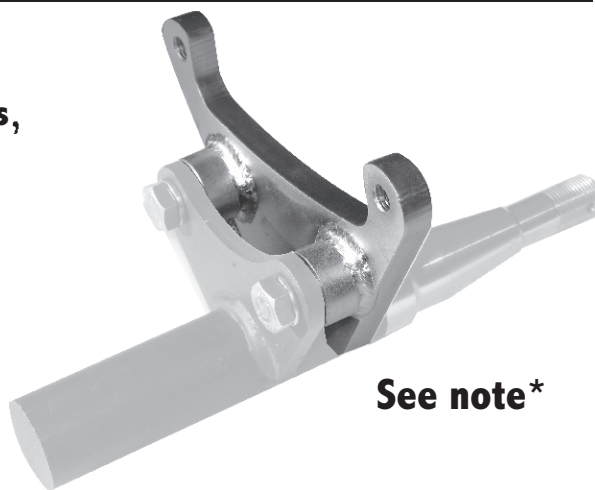

See note*

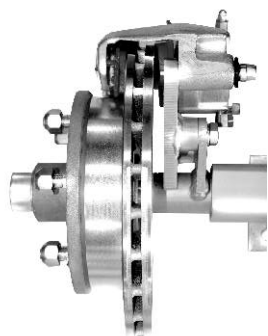

STANDARD AXLE ADAPTOR PLATE*

To Suit RHS Box Section Axle

*Part No. TE192K-TROJAN



DURATORQUE RUBBER SUSPENSION ADAPTOR PLATE*

To Suit Duratorque Rubber Suspension

*Part No. TE192K-TROJAND

***Please note that the above part numbers are for the adaptor plates only. For the disc brake kit part numbers please see the 1500kg range on page 7.**

Kodiak Weld-on 1500kg Brake Conversion Adaptor

Now you can fit Kodiak brakes to unbraked axle beams with bearing combination LM67048 (inner bearing), LM11949 (outer bearing) and bearing spacing of 54mm.

This combination is common to CM, TWL and Trojan MK3 to MK7 (April 1997 onwards).

- Simply weld the bracket to the axle and assemble the brakes.
- All kits are supplied with easy to follow installation instructions.



39mm ROUND STUB AXLE

To Suit 39mm round stub axle

Please contact CM for further information



50mm RHS BOX SECTION

To Suit 50mm RHS Box Section

Please contact CM for further information

HYDRAULIC CALIPERS

2 1/4" Piston and 2 1/2" Piston

Full Stainless Steel or Silver Cadmium Plated Calipers

Now available all stainless as well as cadmium plated. All Kodiak calipers are of a low drag design. This retracts the piston further than the competition which equates to cooler running brakes. All 100% high and low pressure tested.

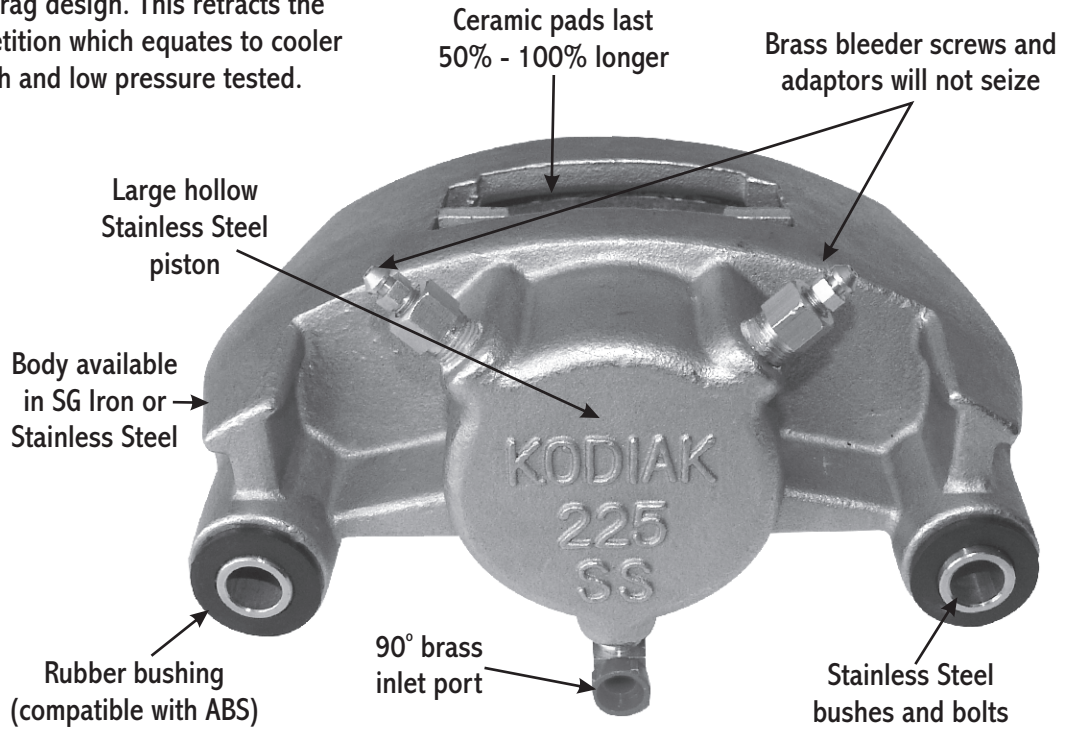

Stainless Steel Calipers - For the ultimate in braking performance in saltwater marine applications. All parts are stainless steel except for the fittings which are all brass - these calipers should never seize.

Silver Cadmium Plated Calipers - Ideal for all non marine applications. Fitted with hollow stainless steel piston, stainless steel slides and mounting bolts, brass bleeders and port adaptor.

Longest warranty in the industry - 6 years Stainless Steel / 3 years Silver Cadmium Plated.

Ceramic Disc Pads - Extreme performance carbon ceramic pad has superior performance, exceptional corrosion protection and a longer service life.

- Stainless steel clips.
- Low dust.
- 50% - 100% longer life. Test results to SAE JZ681.
- Slotted and chamfered pad.
- Double coated polyurethane on backing plate for maximum corrosion protection.
- Integrally moulded construction – hot moulded integrally into the back plate.
- These calipers will not retrofit any other rotor, other than Kodiak.

PART NO	PISTON SIZE	BODY	FITTED TO
TE192KDBC225	2 1/4"	SCAD Plated	1500kg, 1750kg & 2000kg Brakes
TE192KDBC225SS	2 1/4"	STAINLESS STEEL	
TE192KDBC250	2 1/2"	SCAD Plated	3500kg Brakes
TE192KDBC250SS	2 1/2"	STAINLESS STEEL	

VENTED ROTORS

Choose vented rotors from Kodiak for greater heat dissipation, improved braking performance and less susceptibility to brake fade and warpage. All rotors are balanced with minimal runout.



- **Guaranteed performance** - exceeds CSA-D313 test requirements.
- **Vented rotors** - run cooler and improve braking performance.
- **Longest warranty in the industry** - 6 years Stainless Steel / 3 years Silver Cadmium Plated.
- **Proven reliability** - over 20 years in the automotive and 10 years in the trailer industry.
- **Fits most 13"** galvanised spoke boat trailer wheels.

Stainless Steel Rotors



All Stainless offers the ultimate corrosion protection in salt water applications. Negligible rust will form during a 1000 hour standard salt spray test.



Rotor- - SS identifies the rotor as Stainless Steel.



Silver Cadmium Plated (SCAD) Rotors



Made with 35,000psi tensile strength castings for longer rotor life and improved structural integrity. SCAD offers the best value protection, during a standard salt spray test rust will begin forming between 400 and 600 hours.

REPRODUCTION IN WHOLE OR PART IS PROHIBITED WITHOUT WRITTEN APPROVAL

MECHANICAL PARK BRAKE KITS

A mechanical park brake is required by law for trailers over 2500kg GLW - see brake rule 32014, page 126.

CM stock park brake kits for 1500kg, 1750kg, 2000kg and 3500kg hydraulic disc brake sets using the Kodiak mechanical calipers.

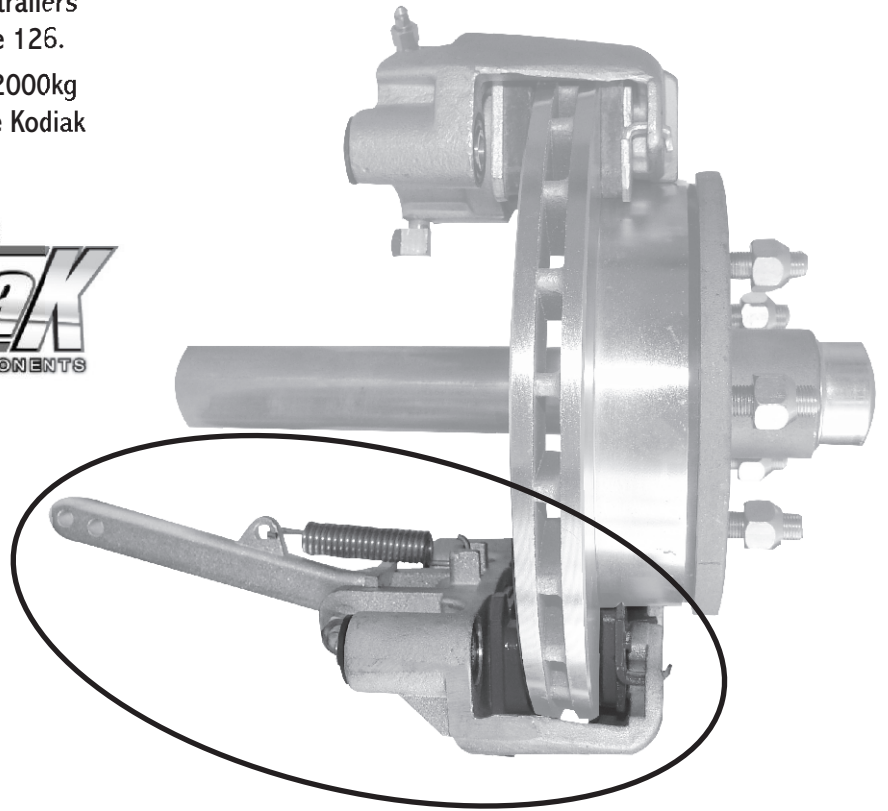
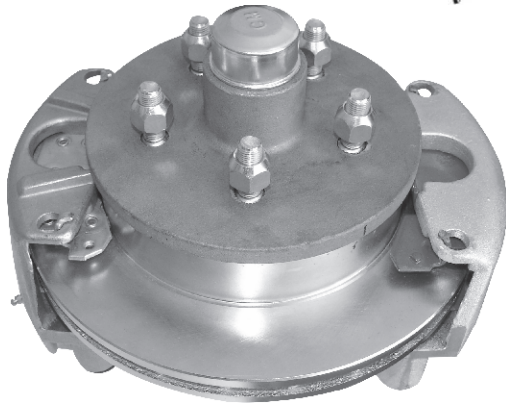

Mechanical Park Brake Kit consists of:

- 2 x Kodiak Calipers with ceramic disc pads and mounting bolts
- Purchased with disc brake sets the 1500kg and 1750kg park brake kits are supplied with twin caliper mount stub axles, whereas twin caliper mounts are standard on the 2000kg and 3500kg.

PARK BRAKE KIT PART NO	FITS	A	B
TE2PBK15	1500kg	158mm	150mm
TE2PBK17	1750kg	158mm	150mm
TE2PBK20	2000kg	158mm	150mm
TE2PBK35	3500kg	162mm	179mm

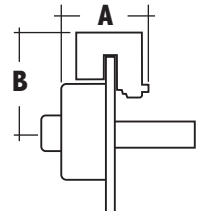

MECHANICAL CALIPERS

Part No. TE192KDBC225PB

You can purchase loose Kodiak calipers as a spare part.

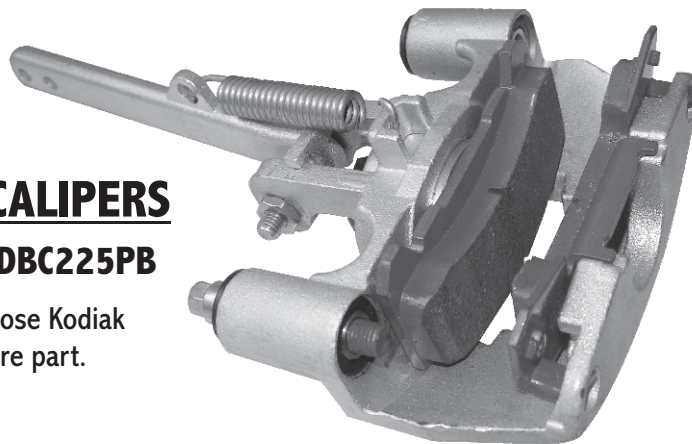

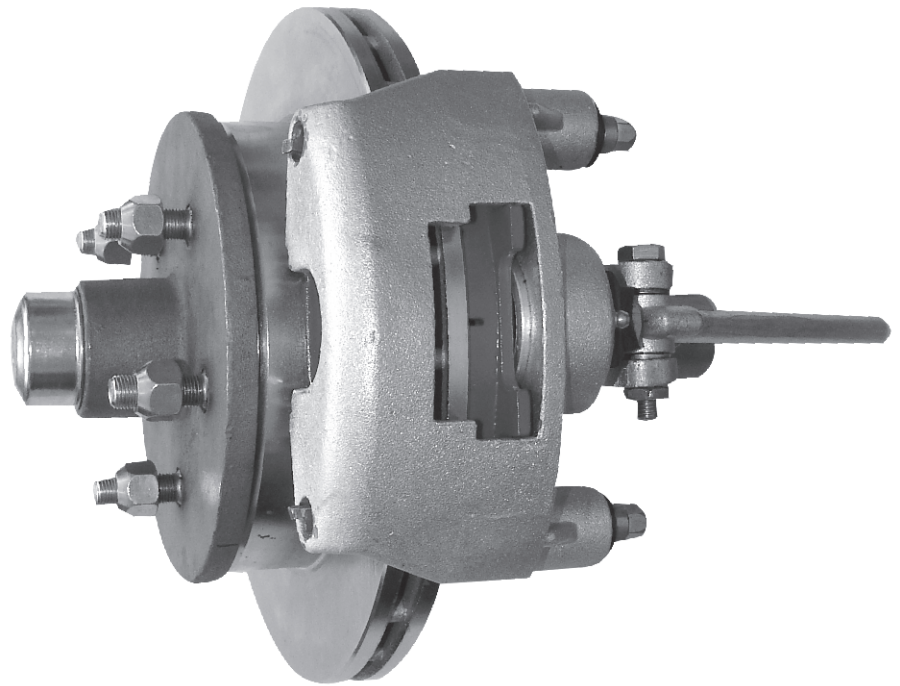

MECHANICAL VENTED DISC BRAKES

Kodiak mechanical disc brakes are a simple means of trailer braking.



- **Guaranteed performance** - exceeds CSA-D313 test requirements.
- **Vented rotors** - run cooler and improve braking performance.
- **Ceramic pads** - improve performance plus 50% - 100% longer pad life.
- **Large diameter rotors** - 11", 22% larger than the opposition, giving more braking force per revolution.
- **Stainless Steel or SCAD plated cast iron rotors** - choose between the two: stainless steel for optimum corrosion resistance or SCAD plated cast iron rotors for the best value for money.
- **Proven reliability** - over 20 years in the automotive and 10 years in the trailer industry.
- **Marine quality triple lip seals** - all these disc brakes are fitted with triple lip marine quality seals for optimum wheel bearing protection.
- **Fits most 13"** galvanised OEM spoke boat trailer wheels and the majority of 14", 15" and 16".

PART NO	CAPACITY PER PAIR	A	B	C	11" ROTOR	CALIPERS	PCD Min-Max (mm)
TE2DIMK151	1500kg	158mm	150mm	39mm	SCAD Plated	SCAD Plated	100-140mm
TE2DIMK154	1500kg	158mm	150mm	39mm	 STAINLESS STEEL	SCAD Plated	100-140mm
TE2DIMK171	1750kg	158mm	150mm	39mm	SCAD Plated	SCAD Plated	100-140mm
TE2DIMK174	1750kg	158mm	150mm	39mm	 STAINLESS STEEL	SCAD Plated	100-140mm
TE2DIMK201	2000kg	158mm	150mm	39mm	SCAD Plated	SCAD Plated	108-140mm
TE2DIMK204	2000kg	158mm	150mm	39mm	 STAINLESS STEEL	SCAD Plated	108-140mm

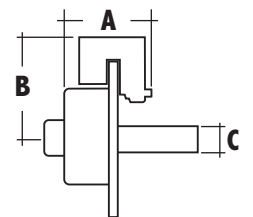

REPRODUCTION IN WHOLE OR PART IS PROHIBITED WITHOUT WRITTEN APPROVAL